

BRADEN Gearmatic

BG4A HYDRAULIC WINCH

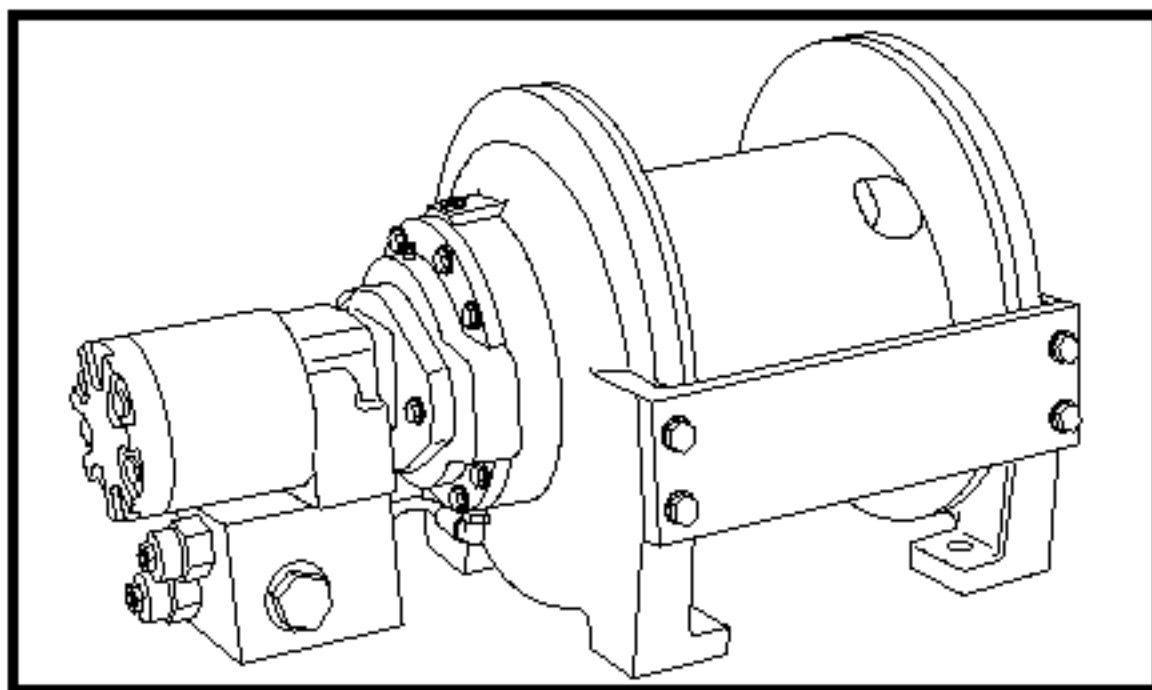

INSTALLATION, MAINTENANCE AND SERVICE MANUAL

PACCAR WINCH DIVISIONS

25-109
497
Printed in U.S.A.

Table of Contents

P.O. BOX 647 · BROKEN ARROW, OK, U.S.A. 74013
PHONE (918) 251-8511 · FAX (918) 258-4322

TABLE OF CONTENTS

	PAGE
FOREWORD	2
PARTS AND SERVICE	2
GENERAL SAFETY RECOMMENDATIONS	3
THEORY OF OPERATION	4
HYDRAULIC CIRCUIT	4
WINCH AND WIRE ROPE INSTALLATION	6
DIMENSIONAL DATA	7
PREVENTIVE MAINTENANCE	8
RECOMMENDED GEAR OIL	9
WINCH EXPLODED VIEW DRAWING	10
BILL OF MATERIAL	11
TROUBLE SHOOTING	12
WINCH SERVICE	15
WINCH DISASSEMBLY	15
DRUM ASSEMBLY SERVICE	16
PLANET CARRIER SERVICE	16
BRAKE CYLINDER ENDPLATE SERVICE	17
WINCH ASSEMBLY	18
FASTENER TORQUE CHART	20
METRIC CONVERSION TABLE	Inside Back Cover

FOREWORD

Read and understand this entire publication before operating or servicing your BRADEN/GEARMATIC winch. Retain this manual for future reference.

The minimum service intervals specified are for operating hours of the prime mover.

The following service instructions have been prepared to provide assembly, disassembly and maintenance information for the Model BG4 series winch. It is suggested that before doing any work on these units, all assembly and disassembly instructions should be read and understood.

Some illustrations in this manual may show details or attachments which may be different from your winch. Also, some components may be removed for illustrative purposes.

Continuing product improvement may cause changes in your winch which may not be included in this manual. When a question arises regarding your winch or this manual, contact your nearest BRADEN/GEARMATIC dealer or the factory Service Department at 918-251-8511, Monday – Friday, 8:00 a.m. to 4:30 p.m. CST, or by Fax at 918-258-4822. Provide the complete winch model number and serial number when making inquiries. The model and serial numbers are stamped into the data plate attached to the base, to the left of the hydraulic motor.

PARTS AND SERVICE

BRADEN/GEARMATIC provides parts and service through a network of authorized dealers. Parts and service are not available directly from the factory. For the name of your nearest dealer, consult your local phone directory or call us at the phone number shown above.

Serial Number and Model Number are located to the left of the hydraulic motor, stamped into the data plate. Always refer to the Serial Number and Model Number when requesting information or service parts.

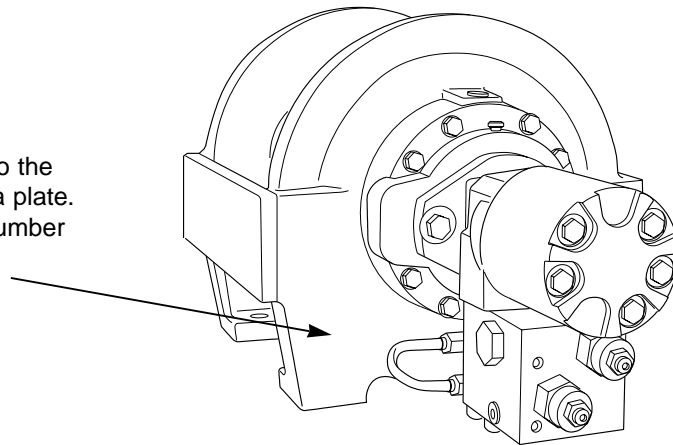

EXPLANATION OF MODEL NUMBER

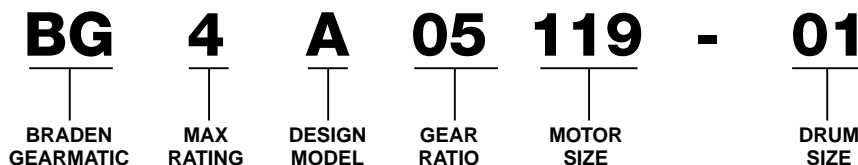

- BG** DESIGNATES BRADEN GEARMATIC
- 4** DESIGNATES 4,000 LB (1,810 kg) FIRST LAYER LINE PULL
- A** DESIGNATES THE MODEL SERIES RELATING TO DESIGN CHANGES
- 05** DESIGNATES TOTAL GEAR REDUCTION
- 119** DCESIGNATES HYDRAULIC MOTOR DISPLACEMENT IN CU IN/REV
DECIMAL POINT ELIMINATED (119 = 11.9 cu in./rev [195 cu cm])
- 01** DESIGNATES THE DRUM

GENERAL SAFETY RECOMMENDATIONS

Safety for operators and ground personnel is of prime concern. Always take the necessary precautions to ensure safety to others as well as yourself. To ensure safety, the prime mover and winch must be operated with care and concern by the operator for the equipment, and a thorough knowledge of the machine's performance capabilities. The following recommendations are offered as a general safety guide. Local rules and regulations will also apply.

⚠ WARNING ⚠

FAILURE TO OBEY THE FOLLOWING SAFETY RECOMMENDATION MAY RESULT IN PROPERTY DAMAGE, PERSONAL INJURY OR DEATH.

1. Read all warning tag information and become familiar with all controls before operating winch.
2. Never attempt to clean, oil or perform any maintenance on a machine with the engine running, unless instructed to do so in the service manual.
3. Never operate winch controls unless you are properly seated at the operators station on the prime mover and you are sure personnel are clear of the work area.
4. Assure that personnel who are responsible for hand signals are clearly visible and that the signals to be used are thoroughly understood by everyone.
5. Ground personnel should stay in view of the prime mover operator and clear of winch drum. Do not allow ground personnel near winch line under tension. A safe distance of at least 1½ times the length of the cable should be maintained.
6. On machines having hydraulically, mechanically and/or cable controlled equipment, be certain the equipment is either lowered to the ground or blocked securely before servicing, adjusting and/or repairing the winch. Always apply the prime mover parking brakes and lower equipment before dismounting the prime mover.
7. Inspect rigging, winch and hydraulic hoses at the beginning of each work shift. Defects should be corrected immediately.
8. Keep equipment in good operating condition. Perform scheduled servicing and adjustments listed in the "Preventive Maintenance" section of this manual.
9. An equipment warm-up procedure is recommended for all start-ups and is essential at ambient temperatures below +40°F. Refer to "Warm-up Procedure" listed in the "Preventive Maintenance" section of this manual.

10. Be sure of equipment stability before operating winch.
11. The winches described herein are neither designed nor intended for use or application to equipment used in the lifting or moving of persons.
12. Do not exceed the maximum pressure (PSI) or flow (GPM) stated in the winch specifications.
13. Operate winch line speeds to match job conditions.
14. Leather gloves should be used when handling winch cable.
15. Never attempt to handle winch cable when the hook end is not free.
16. When winding winch cable on the winch drum, never attempt to maintain tension by allowing winch cable to slip through hands. Always use "hand-over-hand" technique.
17. Never use winch cable with broken strands. Replace winch cable.
18. Do not weld on any part of the winch.
19. Do not use knots to secure or attach winch cable.
20. Use recommended hydraulic oil and gear lubricant.
21. Keep hydraulic system clean and free from contamination at all times.
22. Use correct size cable anchor for cable and pocket in winch drum.
23. The BRADEN/GEARMATIC wire rope anchors are capable of supporting the rated load when installed properly. For additional safety, ALWAYS maintain a minimum of five (5) wraps of wire rope on the drum.

Safety informational callouts used in this manual include:

⚠ WARNING ⚠

WARNING – This emblem is used to warn against hazards and unsafe practices which could result in severe personal injury or death if proper procedures are not followed.

⚠ CAUTION ⚠

CAUTION – This emblem is used to warn against potential or unsafe practices which could result in personal injury or product or property damage if proper procedures are not followed.

THEORY OF OPERATION

DESCRIPTION OF WINCH

The winch has three basic assemblies:

1. Hydraulic motor, brake valve block and counterbalance cartridges
2. Static brake assembly
3. Cable drum assembly

The hydraulic motor is bolted to the motor adapter which in turn is bolted to the brake cylinder end plate of the winch. The cable drum assembly is supported on each end by an anti-friction ball bearing. The ball bearings are located on the end plates and the end plates are connected by two tie plates. The ring gear for the single planetary reduction set is machined into the inside of the cable drum. The cable drum features two anchor pockets for winding cable onto the drum in either direction.

PLANETARY GEAR TRAIN

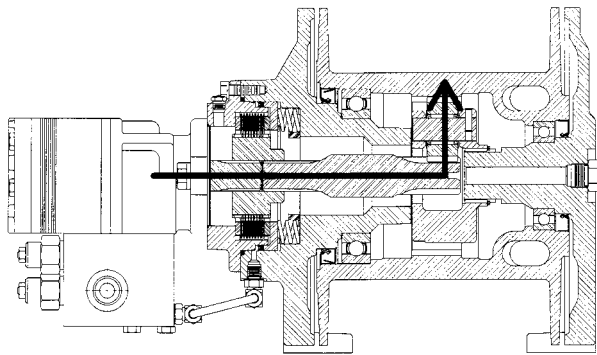

The hydraulic motor shaft is directly splined to the brake coupling which is connected to the sun gear of the planetary reduction set. The planet carrier is splined to the bearing support end plate and cannot rotate. The hydraulic motor rotates the brake coupling and sun gear, driving the planet gears which in turn drive the ring gear/cable drum.

DUAL BRAKE SYSTEM

Dynamic Brake

The dynamic brake system consists of two basic components.

1. Brake valve block and counterbalance cartridges
2. Hydraulic motor

The counterbalance cartridges are installed into a brake valve block which also contains an internal shuttle valve. The shuttle valve directs hydraulic pressure to the brake release port of the winch when the winch is operated in either direction.

Static Brake

The static brake consists of three basic components.

1. Spring applied, multiple friction disk brake pack
2. Solid brake coupling
3. Hydraulic brake cylinder and spring plate.

The brake pack consists of alternately stacked friction and steel brake disks. The steel brake disks are externally splined to the motor adapter and cannot rotate. The friction disks are internally splined to the brake coupling. When the winch is not being operated, spring force compresses the brake pack and locks the brake

HYDRAULIC CIRCUIT

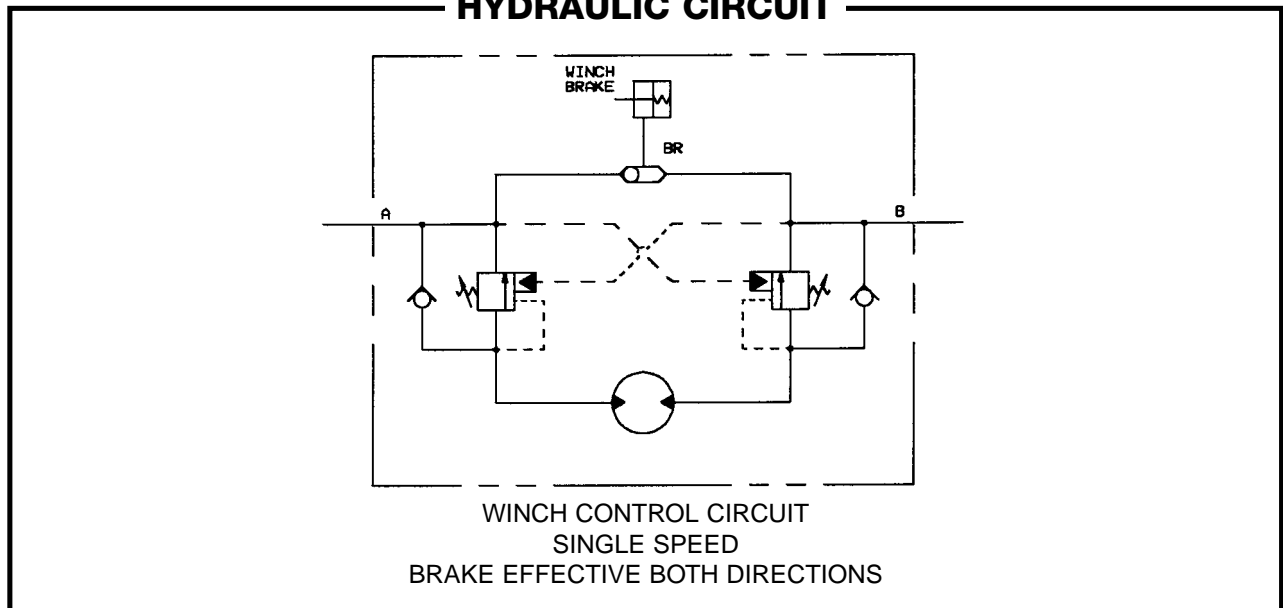

coupling to the motor adapter, preventing the gear train or cable drum from rotating in either direction. The solid brake coupling makes the static brake “effective both directions”. This means the static brake must be released before the winch can operate in either the hoist or lower direction.

The static brake is released by pilot pressure applied to the brake cylinder. It releases at a pressure lower than that required to open the pilot operated counterbalance cartridge. This sequence assures that dynamic braking is done by the counterbalance cartridge and that little, if any, heat is absorbed by the friction brake.

The static or friction brake is primarily a load holding brake and will provide dynamic braking only during extremely slow operation when there is insufficient flow and pressure to open the counterbalance cartridge.

OPERATION

Since the static brake on this winch is “effective both directions”, the brake must be hydraulically released to operate the winch in either the hoist or lower direction.

This also means cable can be wound onto the drum in either direction without any modifications to the winch.

When the winch is powered in either direction, the motor cannot rotate until sufficient pilot pressure is present to open the correct counterbalance cartridge. The friction brake will completely release at a pressure lower than required to open the counterbalance cartridge. The extent to which the cartridge opens will determine the amount of oil that can flow through it and the speed at which the cable drum will turn. Increasing the flow of oil to the winch motor will cause the pressure to rise and the opening in the cartridge to enlarge, speeding up the cable drum. Decreasing this flow causes the pressure to drop and the opening in the cartridge to decrease, slowing down the cable drum.

When the control valve is returned to the neutral or center position, pressure will rapidly drop and the counterbalance cartridge will close, stopping the load. The friction brake will engage and hold the load after the cartridge is closed.

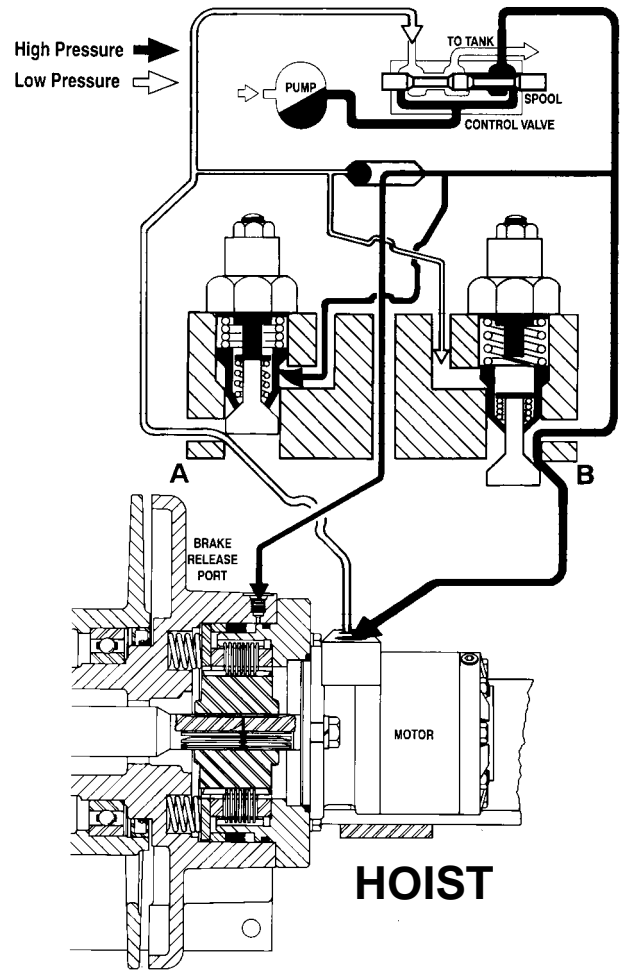
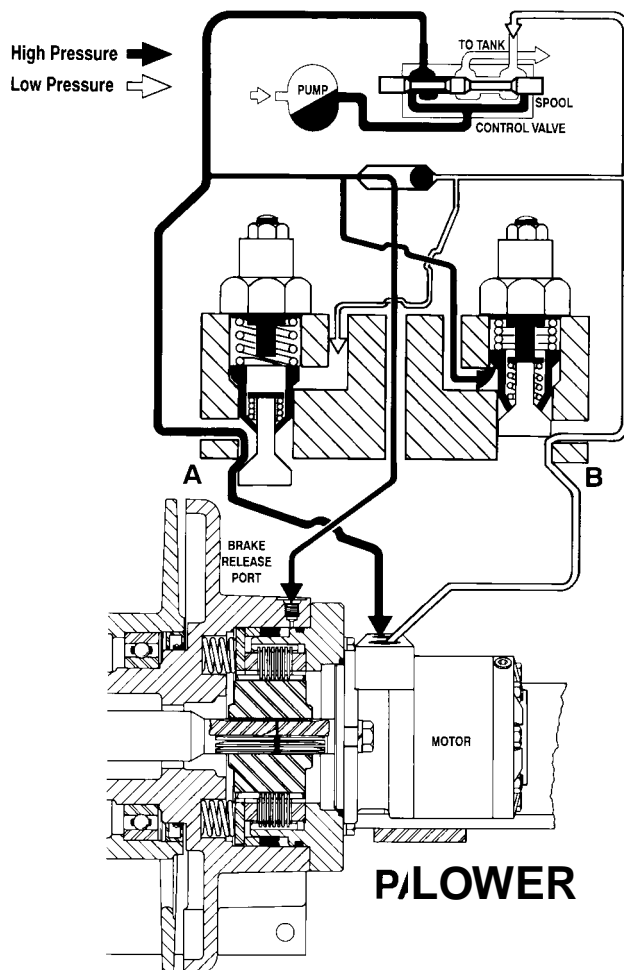

WINCH AND WIRE ROPE INSTALLATION

1. The winch should be mounted with the centerline of the cable drum in a horizontal position. The mounting plane of the winch may be rotated in any position around this centerline providing the vent in the motor adapter is above the centerline of the cable drum. The vent should be as close to top dead center as possible.
2. When mounting the winch, use all four (4) mounting holes and grade eight (8) bolts and nuts. Evenly tighten the nuts to the torque in the “Recommended Fastener Torque” chart.

Refer to “Dimensional Drawing” for bolt hole size and pattern.

It is important that the winch is mounted on a surface that will not flex when the winch is in use, and cause binding of the gear train. Binding in the gear train will result in accelerated wear and heat. Also, the mounting surface should be flat within ± 0.020 inches. If necessary, install shims under the winch mounting pads to achieve even mounting.

3. The hydraulic lines and components that operate the winch should be of sufficient size to assure minimum back pressure at the winch. The back pressure at the motor must not exceed 100 psi (690 kPa) to maintain full brake system design factor and optimum motor seal life.

The winch directional control valve must be a three position four way valve with a motor spool such that when the valve is in the center position both work ports are open to tank (open center, open port).

4. High quality hydraulic oil is essential for satisfactory performance and long hydraulic system component life.

Oil having 150 to 330 SUS viscosity at 100° F (38° C) and viscosity index of 100 or greater will give good results under normal temperature conditions. The use of an oil having a high viscosity index will minimize cold start trouble and reduce the length of warm-up periods. A high viscosity index will minimize changes in viscosity with corresponding changes in temperature.

Maximum cold weather start-up viscosity should not exceed 5,000 SUS with a pour point at least 20° F (11° C) lower than the minimum ambient temperature.

Under continuous operating conditions the temperature of the oil at any point in the system must not exceed 180° F (82° C). 120° F (49° C) to 140° F (60° C) is generally considered optimum.

In general terms:

for continuous operation at ambient temperatures between 50° F (10° C) and 110° F (43° C), use SAE

20W; for continuous operation between 10° F (– 12° C) and 90° F (32° C), use 10W; for applications colder than 10° F (– 12° C), contact the BRADEN/GEAR-MATIC Service Department. The use of multi-viscosity oils is generally not recommended.

For winch gear oil, refer to “Recommended Gear Oil” in the “Preventive Maintenance” section.

5. The hydraulic oil filter should have a 10 micron nominal rating and be full flow type.
6. The vent plug in the motor adapter must be located as close to top dead center as possible. If the winch is mounted on a pivoting surface, the vent plug must remain above the centerline of the cable drum to prevent gear oil leakage.
7. Refer to “Dimensional Drawing” for relationship between drum rotation and which port is pressurized.

WIRE ROPE INSTALLATION

Since the static brake on this winch is “effective both directions”, cable can be wound onto the drum in either direction without any modifications to the winch. The cable drum has two anchor pockets to accommodate this. Take the free end of the wire rope and insert it through the small opening of the anchor pocket you are going to use. Loop the wire rope and push the free end about three-fourths of the way back through the pocket. Install the cable anchor with the small end toward the drum, then pull the slack out of the wire rope. The cable anchor will slip into the pocket and secure the wire rope to the drum. A minimum of five (5) wraps of wire rope should remain on the cable drum at all times. Refer to “General Safety Recommendations” for additional information.

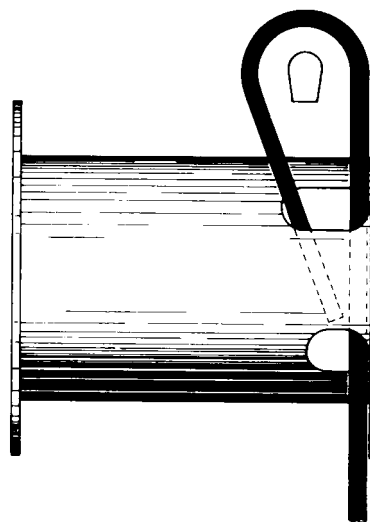

The standard cable anchor wedge supplied with the winch is intended for $\frac{5}{16}$ to $\frac{1}{2}$ in. (8 to 13 mm) wire rope.

DIMENSIONAL DATA (Inches)

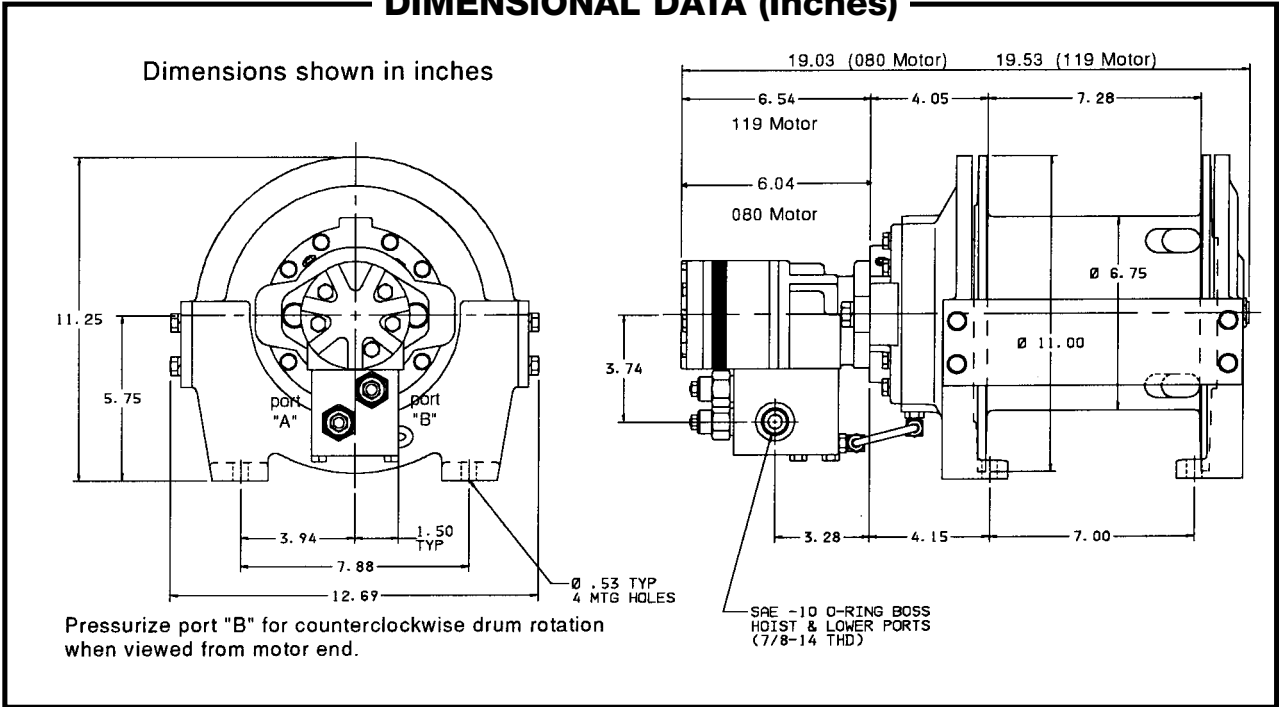

DIMENSIONAL DATA (millimeters)

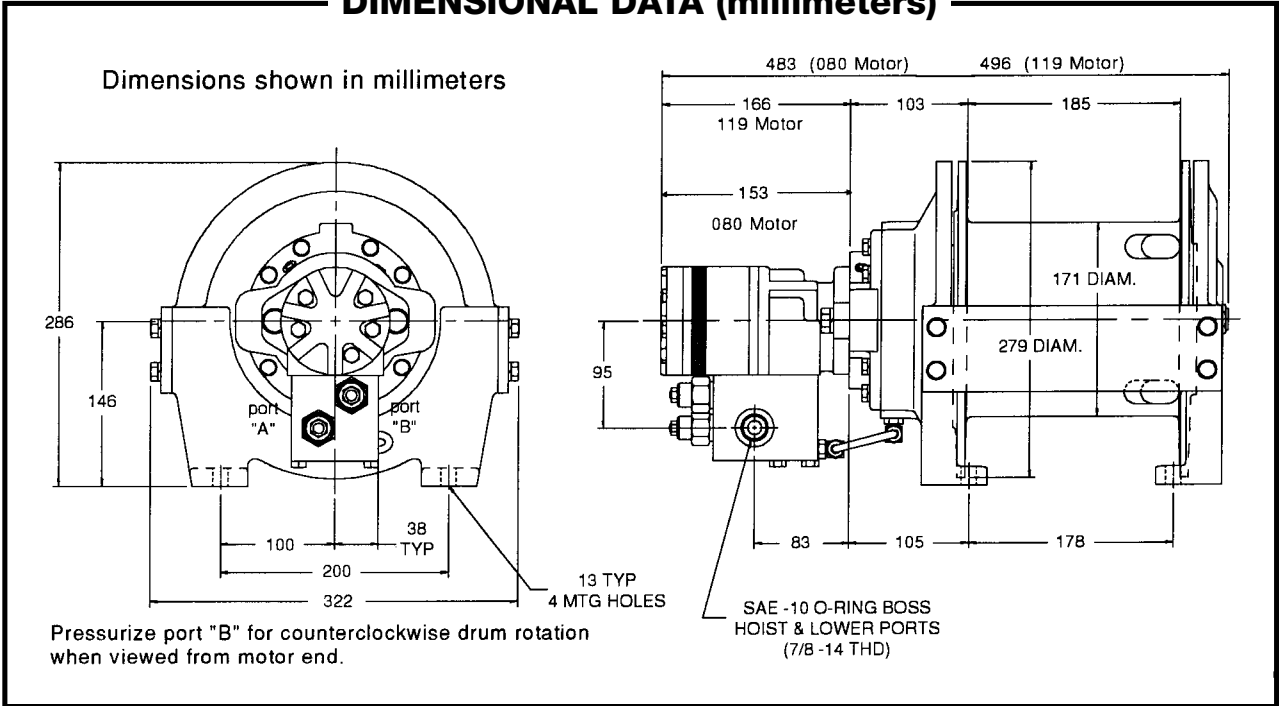

PREVENTIVE MAINTENANCE

A regular program of preventive maintenance for your planetary winch is strongly recommended to minimize the need for emergency servicing and promote safe, reliable winch operation

Field experience supported by engineering tests, indicates the three (3) service procedures listed below are the **MOST** critical to safe, reliable winch operation and must be observed.

- **Regular Gear Oil Changes** – every 1000 hours or six (6) months.
- **Use of Proper Gear Oil** – recommended type for prevailing ambient temperature.
- **Annual Disassembly and Inspection of All Wear Items** – in compliance with American National Standards Institute (ANSI) specification B30.5c 1987 and American Petroleum Institute (API) recommended practice RP 2D section 3.

The following minimum service intervals are specified for operating hours of the prime mover.

1. Oil Level

The gear oil level should be checked every 500 operating hours or three (3) months, whichever occurs first. To check the oil level, remove the large plug located in the center of the drum support. The oil should be level with the bottom of this opening. If additional oil is needed, refer to “Recommended Planetary Gear Oil”.

2. Oil Change

The gear oil should be changed after the first one hundred (100) hours of operation, then every 1,000 operating hours or six (6) months, whichever occurs first. The gear oil must be changed to remove wear particles that impede the reliable and safe operation of the brake clutch and erode bearings, gears and seals. Failure to change gear oil at these suggested minimum intervals may contribute to intermittent brake slippage which could result in property damage, severe personal injury or death.

The gear oil should also be changed whenever the ambient temperature changes significantly and an oil from a different temperature range would be more appropriate. Oil viscosity with regard to ambient temperature is critical to reliable brake operation. Make certain that the gear oil viscosity used in your winch is correct for your prevailing ambient temperature. Failure to use the proper type and viscosity of planetary gear oil may contribute to brake slippage which could result in property damage, severe personal injury or death. Refer to “Recommended Planetary Gear Oil” for additional information.

3. Vent Plug

The vent plug is located in the motor adapter. It is very important to keep this vent clean and unobstructed. Whenever gear oil is changed remove vent plug, clean in solvent and reinstall.

Do not paint over the vent or replace with a solid plug.

4. Hydraulic System

The original filter element should be replaced after the first fifty (50) hours of operation, then every 500 operating hours or three (3) months, or in accordance with the equipment manufacturer’s recommendations.

5. Wire Rope

Inspect entire length of wire rope according to wire rope manufacturer’s recommendations.

6. Mounting bolts

Tighten all winch base mounting bolts to recommended torque after the first one hundred (100) hours of operation, then every 1000 operating hours or six (6) months, whichever occurs first.

7. Warm-up procedure

A warm-up procedure is recommended at each start-up and is essential at ambient temperatures below +40°F (4°C).

The prime mover should be run at its lowest recommended RPM with the hydraulic winch control valve in neutral allowing sufficient time to warm up the system. The winch should then be operated at low speeds, forward and reverse, several times to prime all lines with warm hydraulic oil, and to circulate gear lubricant through the planetary gear sets.

⚠ WARNING ⚠

Failure to properly warm up the winch, particularly under low ambient temperature conditions, may result in temporary brake slippage due to high back pressures attempting to release the brake, which could result in property damage, severe personal injury or death.

8. Recommended Planetary Gear Oil

Field experience, supported by extensive engineering tests, indicates the use of the proper planetary gear oil is essential to reliable and safe operation of the brake and obtaining long gear train life.

For simplicity, we have listed one (1) readily available product in each temperature range which has been tested and found to meet our specifications. This is not to say that other lubricant brands would not perform equally as well

If the following lubricant brands are not available in your area, make certain your lubricant vendor supplies you with oil that is equivalent to those products listed below.

BG4A Planetary winches are factory filled with Texaco Meropa 150 or equivalent.

9. Inspection

In compliance with ANSI specification number B30.5c1987 and API Recommended Practice RP 2D section 3, we recommend that the winch be disassembled for a thorough inspection of all wear items every 2,000 hours of operation or twelve (12) months, whichever occurs first.

! WARNING !

Failure to use the proper type and viscosity of planetary gear oil may contribute to intermittent brake slippage which could result in property damage, severe personal injury or death. Some gear lubricants contain large amounts of EP (extreme pressure) and anti-friction additives which may contribute to brake slippage and damage to brake friction discs or seals. Oil viscosity with regard to ambient temperatures is also critical to reliable brake operation. Our tests indicate that excessively heavy or thick gear oil may contribute to intermittent brake slippage. Make certain that the gear oil viscosity used in your winch is correct for your prevailing ambient temperature.

RECOMMENDED GEAR OIL

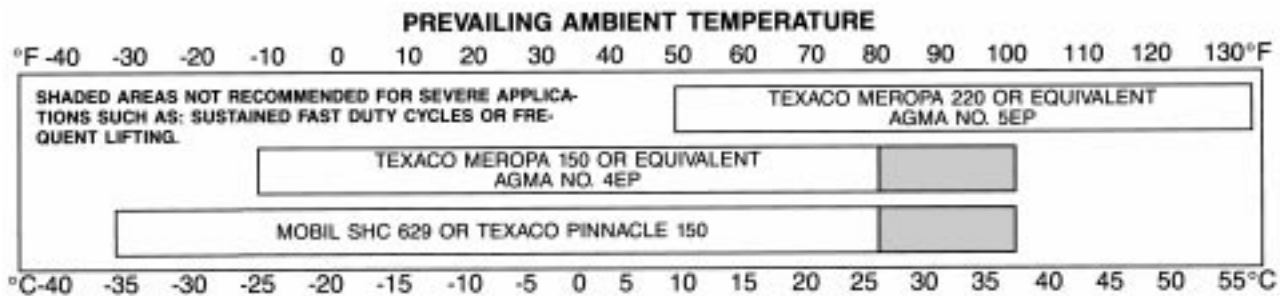

BG4 winches are factory filled with Texaco Meropa 150 or equivalent gear oil. Oil capacity is 2 pints.

BRADEN/GEARMATIC BG4A COMPONENTS

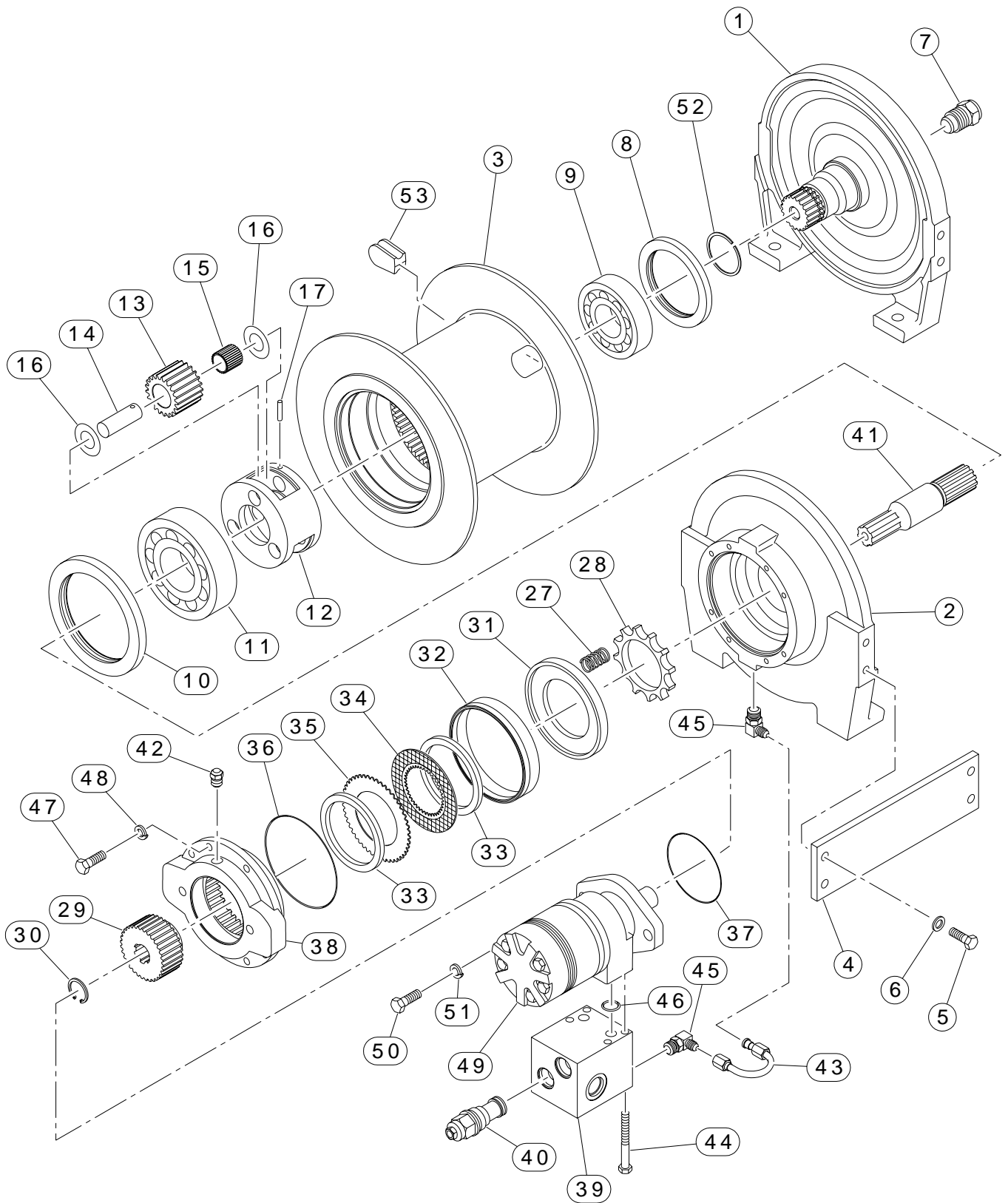

BRADEN/GEARMATIC BG4A BILL OF MATERIAL

BG4A PARTS KEY		
ITEM NO.	DESCRIPTION	QTY.
1	BEARING SUPPORT ENDPLATE	1
2	BRAKE CYLINDER ENDPLATE	1
3	CABLE DRUM	1
4	TIEPLATE	2
5	CAPSCREW (3/8-16 x 1 Gr5)	8
6	LOCKWASHER (3/8)	8
7	SIGHT GAUGE	1
8	OIL SEAL	1
9	BALL BEARING	1
10	OIL SEAL	1
11	BALL BEARING	1
12	OUTPUT PLANET CARRIER	1
13	OUTPUT PLANET GEAR	3
14	OUTPUT PLANET GEAR SHAFT	3
15	ROLLER BEARING	3
16	THRUST RACE	6
17	ROLLPIN	3
27	SPRING	8
28	SPRING LOCATOR	1
29	BRAKE COUPLING	1
30	SNAP RING	1
31	SPRING PLATE	1
32	BRAKE PISTON SEAL	1
33	BRAKE PLATE SPACER	2
34	FRICTION DISK	8
35	STEEL DISC	9
36	O-RING	1
37	O-RING	1
38	MOTOR ADAPTER	1
39	BRAKE VALVE BLOCK	1
40	COUNTERBALANCE VALVE CARTRIDGE	2
41	SUN GEAR	1
42	VENT PLUG	1
43	TUBE ASSEMBLY	1
44	CAPSCREW (5/16-18 x 3 1/2 Gr5)	4
45	ELBOW FITTING	2
46	O-RING	2
47	CAPSCREW (5/16-18 x 1 Gr5)	8
48	LOCKWASHER (5/16)	8
49	HYDRAULIC MOTOR	1
50	CAPSCREW (1/2-13 x 1 1/4 Gr5)	2
51	LOCKWASHER (1/2)	2
52	SNAP RING	1
53	CABLE WEDGE	1

TROUBLE SHOOTING

TROUBLE	PROBABLE CAUSE	REMEDY
<p>A.</p> <p>Winch will not pull maximum load.</p>	<ol style="list-style-type: none"> 1. System relief valve may be set too low 2. If this trouble occurs suddenly after working at maximum pull, a particle of dirt may be lodged under the system relief valve, holding it partially open. If this is the cause, a considerable loss in line speed may be noticed as the load on the cable is increased. 3. If the pump is belt driven, the belts may be slipping. 4. The oil level in the reservoir may be too low. The suction line may be restricted or have an air leak causing cavitation at the inlet port. This will cause the pump to make a whining noise. 5. The winch may be mounted on an uneven or flexible surface which causes distortion of the winch base and binding of the gear train. Binding in the gear train will absorb horsepower needed to generate the rated line pull and cause heat. 6. Be certain hydraulic system temperature is not more than 180° F (82° C). Excessive hydraulic oil temperatures increase motor internal leakage and reduce motor performance. 7. Winch line pull rating is based on 1st layer of wire rope. Expected line pull may be in excess of winch rating. 8. After all the causes listed above have been investigated and it is found that the winch will stall at maximum pressure without developing the maximum pull on the bare drum, the trouble may be in the winch. 9. Rigging and sheaves not operating efficiently. 	<p>Install a pressure gauge in the haul-in port and apply a stall pull on the winch. If pressure is low, increase relief valve setting until recommended pressure is obtained.</p> <p>NOTE: If pressure does not increase in proportion to adjustment, relief valve may be contaminated or worn out. In either case, the relief valve may require disassembly or replacement.</p> <p>Remove relief valve, disassemble and clean parts thoroughly in a suitable solvent. Reassemble and install relief valve. Reset pressure according to specifications.</p> <p>Check belts when pump is at full PSI (kg/cm²) (stall pull on winch). Tighten belts if they are found to be slipping.</p> <p>Check oil level in the reservoir. Check the suction line for damage, externally and internally. Replace suction line if necessary.</p> <p>Reinforce mounting surface.</p> <p>If necessary, use steel shim stock to level winch.</p> <p>First loosen, then evenly retighten all winch mounting bolts to recommended torque.</p> <p>Same as remedy for A-5.</p> <p>Same as remedy for B-4.</p> <p>Refer to winch performance charts for additional information</p> <p>Install a pressure gauge in the motor haul-in port and apply a stall pull on the winch. If the pressure is up to maximum and the bare drum line pull is less than the specified line pull, the trouble will be in the winch.</p> <p>Disassemble winch according to disassembly instructions and check that gear train turns freely. If gear train is found to be satisfactory, inspect the hydraulic motor, according to the service instructions for the hydraulic motor.</p> <p>Perform rigging and sheave service as recommended by manufacturer.</p>

TROUBLE SHOOTING

TROUBLE	PROBABLE CAUSE	REMEDY
<p>B.</p> <p>Considerable reduction in line speed.</p>	<ol style="list-style-type: none"> 1. Same as A-2. 2. Same as A-4. 3. Same as A-6. 4. If this trouble has increased gradually, the hydraulic pump or winch motor may be worn. 	<p>Same as remedy for A-2.</p> <p>Same as remedy for A-4.</p> <p>Same as remedy for A-5 & B-4.</p> <p>Remove and inspect pump. If satisfactory, consult the disassembly instructions for the winch and remove and inspect the motor according to the service instructions for the hydraulic motor.</p>
<p>C.</p> <p>Reverse speed is slower than forward speed.</p>	<ol style="list-style-type: none"> 1. Control valve may be restricted in its travel. 2. Same as A-1. 3. Oil may be too thick causing a high resistance to rotation at the brake plates and causing the relief valve to by-pass. 4. Same as F-1. 	<p>Check the travel of the control valve spool. The spool travel should be the same in both directions.</p> <p>Same as remedy for A-1.</p> <p>Follow warm-up procedure in "Preventive Maintenance" section.</p> <p>Same as remedy for F-1.</p>
<p>D.</p> <p>Brake will not hold when control valve is returned to neutral after lifting a load.</p>	<ol style="list-style-type: none"> 1. Excessive system back pressure acting on the brake release prot. 2. Friction brake will not hold due to worn or damaged brake disks. 	<p>Install a pressure gauge at the "pay-out" port of the hydraulic motor. Operate the pump at full throttle and monitor pressure in "neutral" and haul-in positions. If the pressure is greater than 50 PSI, check for restrictions in the return line from the winch to the control valve and the control valve to the reservoir.</p> <p>Disassemble winch to inspect/replace worn parts.</p>
<p>E.</p> <p>Brake will not control or stop the load when lowering.</p>	<ol style="list-style-type: none"> 1. Same as D-1 or 2. 2. Winch is being overloaded. 3. After the causes listed above have been investigated and found to be satisfactory, the trouble may be in the winch. 	<p>Same as remedy for D-1 or 2.</p> <p>Install a pressure gauge at the haul-in port and apply a stall pull on the winch. If the pressure is higher than the maximum specified PSI, reduce the pressure.</p> <p>Disassemble the brake assembly according to the disassembly instructions. Inspect the brake springs, and brake plates.</p>

TROUBLE SHOOTING

TROUBLE	PROBABLE CAUSE	REMEDY
<p>F.</p> <p>The winch will not lower the load or not lower the load smoothly.</p>	<ol style="list-style-type: none"> 1. The friction brake may not be releasing as a result of a defective brake cylinder seal. <li style="padding-left: 20px;">NOTE: If the brake cylinder seal is defective you will usually notice oil leaking from the winch vent plug. 2. Friction brake will not release as a result of damaged brake disks. 3. Same as B-4. 4. Same as A-3. 5. Same as A-5. 6. Control valve handle being operated too quickly. 7. Insufficient gear oil in cable drum. 8. Control valve does not have good metering characteristics. 	<p>Disassemble and inspect the brake cylinder seal.</p> <p>Disassemble brake to inspect brake disks.</p> <p>Same as remedy for B-4.</p> <p>Same as remedy for A-3.</p> <p>Same as remedy for A-5.</p> <p>Operate control valve smoothly when starting and stopping a load. Conduct operator training as required.</p> <p>Remove oil level plug and check oil level. Fill to proper level.</p> <p>See "Winch Installation" section for control valve specifications.</p>
<p>G.</p> <p>The winch runs hot.</p>	<ol style="list-style-type: none"> 1. Same as A-5. 2. Be certain that the hydraulic system temperature is not more than 180 degrees F. Excessive hydraulic oil temperatures may be caused by: <ol style="list-style-type: none"> A. Plugged heat exchanger. B. Too low or too high oil level in hydraulic reservoir. C. Same as A-1. D. Hydraulic pump not operating efficiently. 3. Excessively worn or damaged internal winch parts. 4. Same as F-7. 	<p>Same as remedy for A-5.</p> <p>Thoroughly clean exterior and flush interior. Fill/drain to proper level.</p> <p>Same as remedy for A-1.</p> <p>Remove and inspect pump.</p> <p>Check suction line for damage. If pump is belt driven, belts may be slipping. Replace/tighten belts.</p> <p>Disassemble winch to inspect/replace worn parts.</p> <p>Same as remedy for F-7.</p>
<p>H.</p> <p>Winch "chatters" while raising rated load.</p>	<ol style="list-style-type: none"> 1. Same as A-1. 2. Same as B-4. 3. Hydraulic oil flow to motor may be too low. 4. Same as F-6. 	<p>Same as remedy for A-1.</p> <p>Same as remedy for B-4.</p> <p>Increase pump rpm.</p> <p>Same as remedy for F-6.</p>

WINCH SERVICE

FOREWORD TO WINCH SERVICE

Before any part is removed from the winch, all service instructions should be read and understood.

Work in a clean, dust free area as cleanliness is of utmost importance when servicing hydraulic equipment.

Inspect all replacement parts, prior to installation, to detect any damage which might have occurred in shipment.

Use only genuine BRADEN/GEARMATIC replacement parts for optimum results. Never reuse expendable parts such as oil seals and o-rings.

Inspect all machined surfaces for excessive wear or damage . . . before reassembly operations are begun.

Lubricate all o-rings and oil seals with gear oil prior to installation.

Use a sealing compound on the outside surface of oil seals and a light coat of thread sealing compound on pipe threads. Avoid getting thread compound inside parts or passages which conduct oil.

Thoroughly clean all parts in a good grade of non-flammable safety solvent. Wear protective clothing as required.

Refer to exploded view drawing for item numbers used in service procedures.

- Perform all applicable trouble shooting operations BEFORE disassembling winch.

⚠ WARNING ⚠

DO NOT CLEAN BRAKE FRICTION DISKS IN SOLVENT. SOLVENT MAY CAUSE DAMAGE TO FRICTION MATERIAL WHICH MAY RESULT IN BRAKE FAILURE AND LOSS OF LOAD CONTROL.

WINCH DISASSEMBLY

1. Disconnect all hoses and fittings at the winch.

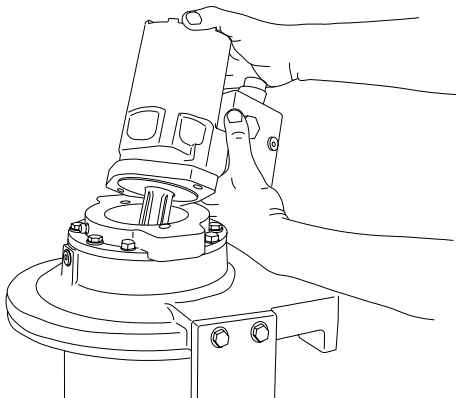

2. Stand the winch on the bearing support end plate. Remove the brake release tube assembly (43)

between the brake valve block and the brake cylinder end plate. Remove the capscrews (50) and lockwashers (51) which secure the motor (49) to the motor adapter (38), and lift the motor out of the motor adapter. Remove and discard the o-ring (37) installed on the pilot of the motor.

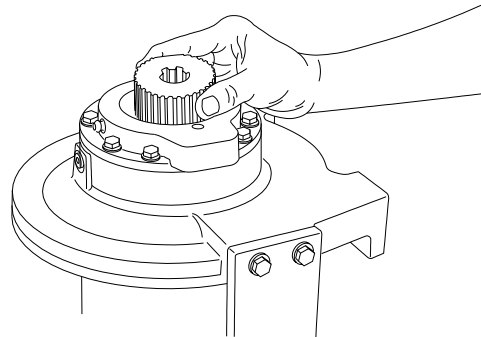

3. Remove the brake coupling (29) and sun gear (41) from the winch.

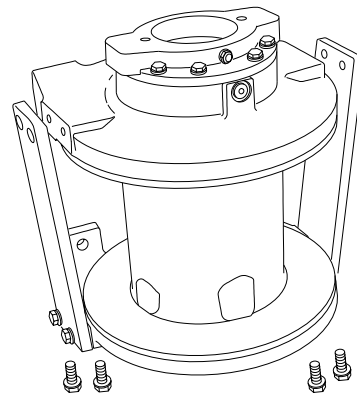

4. Remove the four capscrews (5) and lockwashers (6) holding the tieplates (4) to the brake cylinder endplate. Remove the brake cylinder endplate from the drum

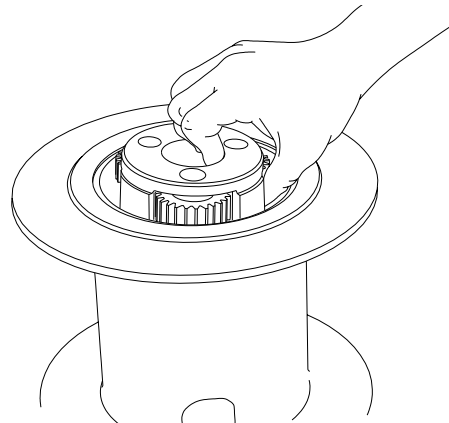

5. Remove the other four capscrews and lockwashers holding the tieplates to the bearing support endplate. Remove the planet assembly from the drum and separate the drum from the bearing support endplate.

DRUM ASSEMBLY SERVICE

1. Remove the bearing and seal from each end of the drum. Thoroughly clean and inspect the drum. Check the ring gear teeth (machined into the inside surface of the drum) for nicks, spalling or excessive wear. Replace the drum if wear is greater than 0.015 in. (0.4 mm) when compared to unworn area of teeth.

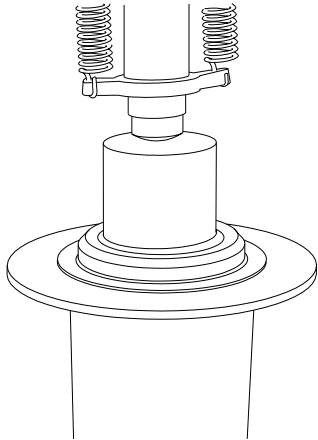

2. Install new bearings in the drum if replacement is necessary. Apply a non-hardening sealant on the outside diameter of each new seal and press the seals into the drum, using a flat plate to avoid distortion.

PLANET CARRIER SERVICE

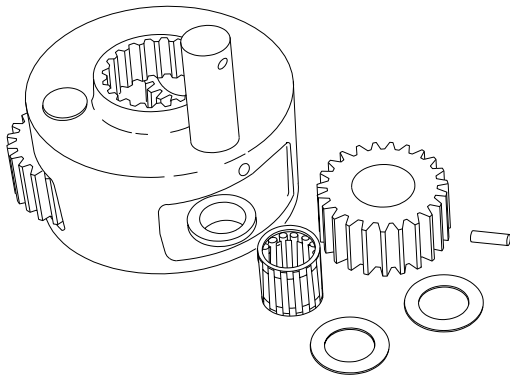

1. First drive the rollpins (17) into the center of the planet pins (14). Now you can remove the planet shaft (14), two thrust races (16), planet gear (13) and roller bearing (15). Repeat this procedure for the other two planet gears. Thoroughly clean all parts and inspect for damage and wear. The bearing rollers should not exhibit any irregularities. If the rollers show any sign of spalling, corrosion, discoloration, material displacement or abnormal wear, the bearing

should be replaced. Likewise, the cage should be inspected for unusual wear or deformation, particularly the cage bars. If there is any damage that will impair the cage's ability to separate, retain and guide the rollers properly, the bearing should be replaced. The thrust washer contact areas should be free from any surface irregularities that may cause abrasions or friction. The gears and shafts should be inspected for abnormal wear or pitting. Replace if necessary.

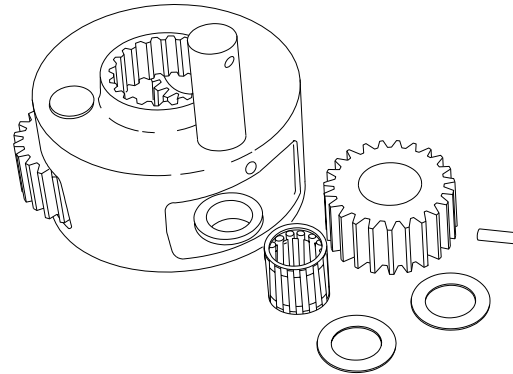

2. Insert a bearing into a planet gear and place a thrust race on each side of the gear. Position this assembly in the planet carrier and slide the planet gear shaft through the carrier. Align the pin hole in the shaft with the hole in the carrier and drive a NEW rollpin into place. **Always use NEW rollpins.** When properly positioned, the rollpin will be slightly below the surface of the carrier.

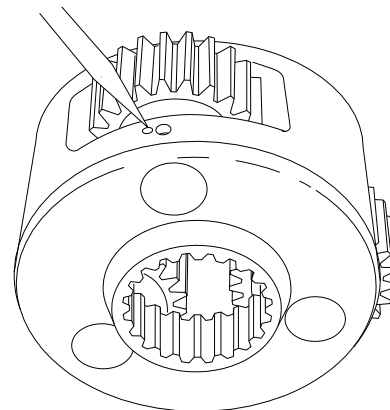

3. With a center punch, stake the carrier next to the pin hole as shown. This will distort the hole so the pin will not back out when in service. Repeat these steps for each of the three planet gears.

BRAKE CYLINDER ENDPLATE SERVICE

Disassembly and Inspection

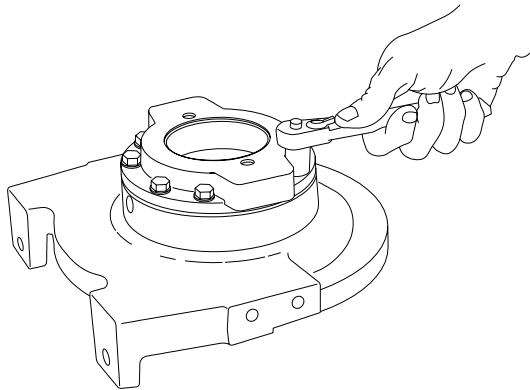

1. NOTE: The capscrews in the motor adapter should be evenly removed in 1 or 2 turn increments since the motor adapter is under spring tension. Remove the capscrews (47) and lockwashers (48) holding the motor adapter (38) to the endplate (2). Install 2 capscrews and a short piece of chain into the motor mounting holes. Using the chain as a handle, lift the motor adapter out of the endplate. Remove and discard the O-ring (36) from the motor adapter. Remove and discard the brake piston seal (32). Remove brake plate spacers (33), steel discs (35), friction discs (34), spring plate (31), springs (27) and spring spacer (28).

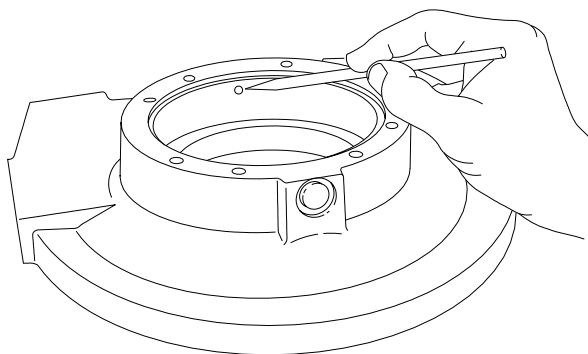

2. Thoroughly clean and inspect all parts at this time. Check brake piston sealing surfaces on motor adapter and brake cylinder endplate. Be sure the brake release port in the endplate (shown above) is free of contamination. Remove the vent plug (42) from the motor adapter, clean in solvent and reinstall. DO NOT paint over the vent or replace it with a solid plug.

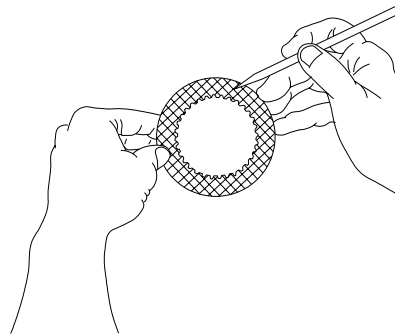

3. Place each friction disc on a flat surface and check for distortion with a straight edge. Friction material should appear even across entire surface with groove pattern visible. Replace friction disc if splines are worn to a point, disc is distorted, friction material is worn unevenly or groove pattern is worn away. Place each steel disc on a flat surface and check for distortion with a straight edge. Check surface for signs of material transfer or heat. Replace steel disc if splines are worn to a point, disc is distorted or heat discolored.

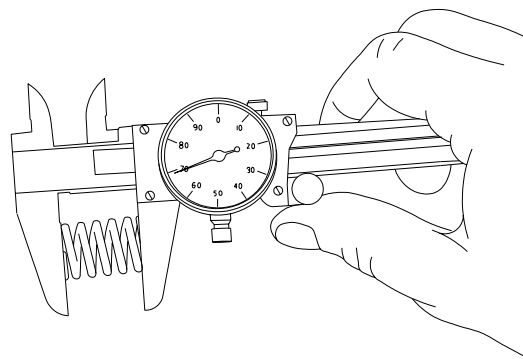

4. Check free length of each brake spring. Minimum free length is 15/16 inch (23.8 mm). Check springs for any signs of cracking or failure. If a brake spring must be replaced for any reason, then ALL brake springs must be replaced.

CAUTION

Failure to replace brake springs as a set may result in uneven brake application pressure and repeated brake spring failure.

WINCH ASSEMBLY

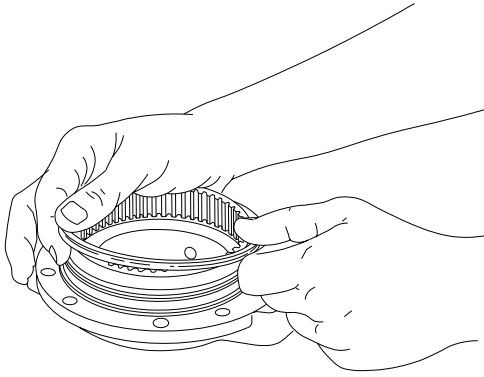

1. Place the motor adapter on workbench with the motor mounting surface down. Install a new O-ring (36). Lubricate the brake piston seal with petroleum jelly or hydraulic oil and install on the motor support with the seal lip down, as shown above.

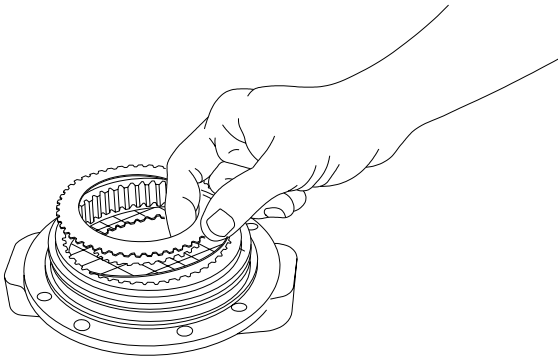

2. Install a brake spacer (33) into the motor support. Insert a steel disc (35) against the spacer, followed by a friction disc (34). Alternately install steel and friction discs until eight (8) friction discs and nine (9) steel discs have been installed. Finish with a steel disc on top.

NOTE: It is a good practice to lubricate the discs in gear oil prior to assembly.

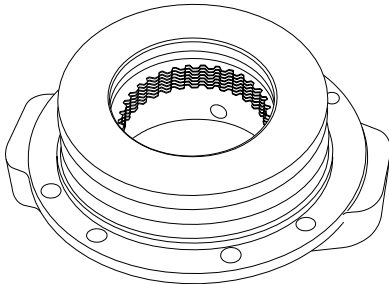

3. Install the other brake plate spacer (33) and the spring plate (31) as shown.

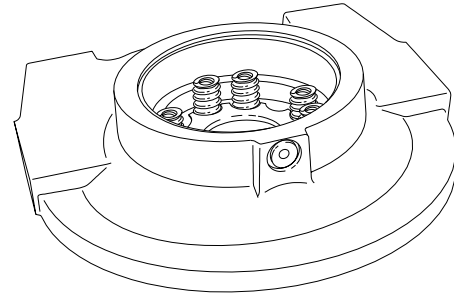

4. Install the spring locator (28) and the eight (8) springs (27) into the brake cylinder end plate (2).

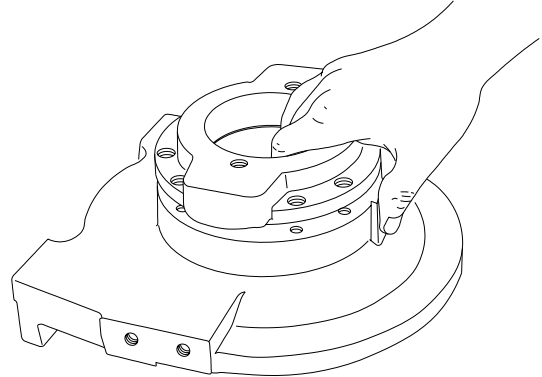

5. While holding the motor adapter and brake assembly together, turn it over and install into the brake cylinder end plate. Install the eight (8) capscrews (47) and lockwashers (48) but do not tighten them at this time.

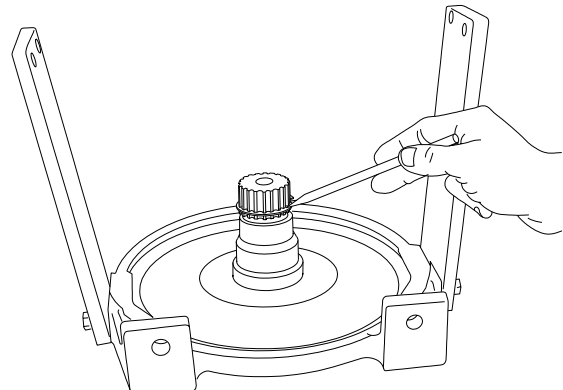

6. Loosely attach the two tie plates (4) to the bearing support end plate using capscrews (5) and lockwashers (6).

⚠ CAUTION ⚠

Make certain the snap ring is installed on the bearing support. This snap ring will keep the planet carrier correctly positioned in the winch. Gear train damage may occur if this snap ring is omitted.

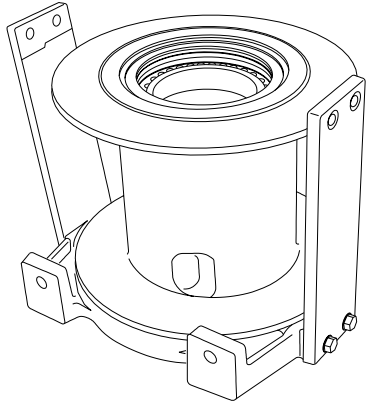

7. Lubricate the bearing support and sealing surface with petroleum jelly or gear oil and place the cable drum (3) on the bearing support endplate. Check that the drum rotates freely on the bearing.

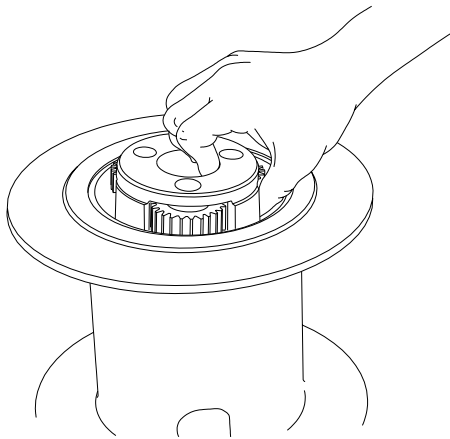

8. Install the planet carrier assembly into the drum while meshing the planet gears with ring gear and the planet carrier with the bearing support.

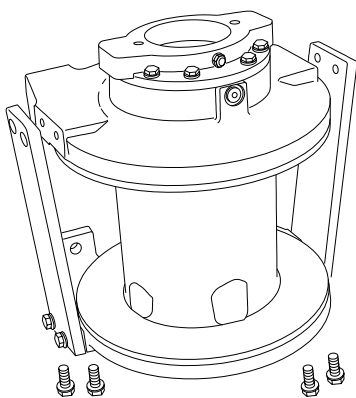

9. Lubricate the bearing support and sealing surface on the brake cylinder endplate and install the endplate assembly onto the drum.

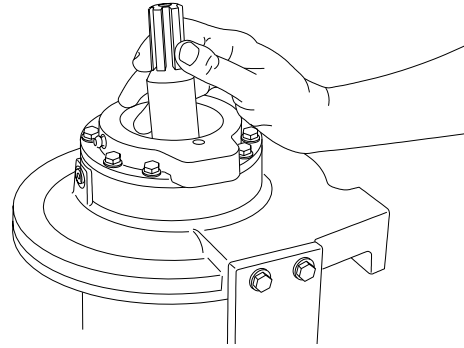

10. Fasten the two tie plates to the endplate with cap screws (5) and lockwashers (6), and torque all eight (8) tie plate cap screws to their proper value. Check that the drum turns freely in both directions without binding or any interference. Install the sun gear (41), meshing with the teeth on the planet gears in the drum.

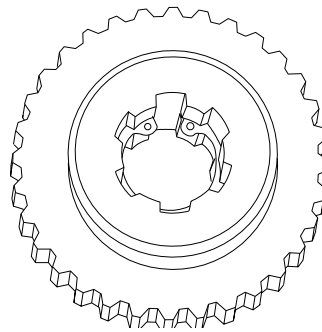

⚠ WARNING ⚠

Be certain the snap ring (30) is seated in the groove in the splined bore of the brake coupling (29). This snap ring will keep the brake coupling correctly positioned in the center of the friction brake pack. Binding of the brake or brake failure may occur if this snap ring is omitted.

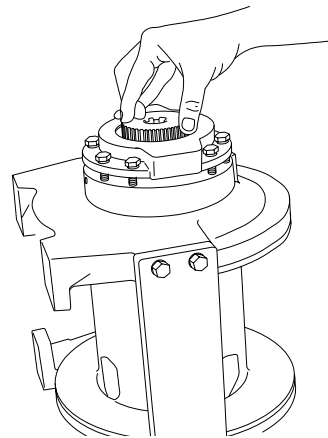

11. Install the brake coupling into the brake pack with the flat end of the coupling toward the motor. Turn the coupling back and forth to align the outer splines

with the brake disc splines. The coupling must engage all the brake discs and the snap ring in its center must rest on the sun gear. Evenly tighten the eight (8) capscrews around the motor adapter one turn at a time until the motor adapter is firmly seated to the endplate. Torque the capscrews to their proper value.

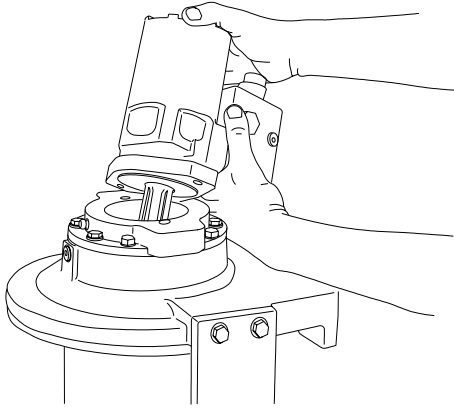

12. Install a new O-ring (37) on the motor pilot and lubricate with petroleum jelly or gear oil. Install the motor onto the motor adapter with two capscrews (50) and lockwashers (51). Torque the capscrews to their proper value.

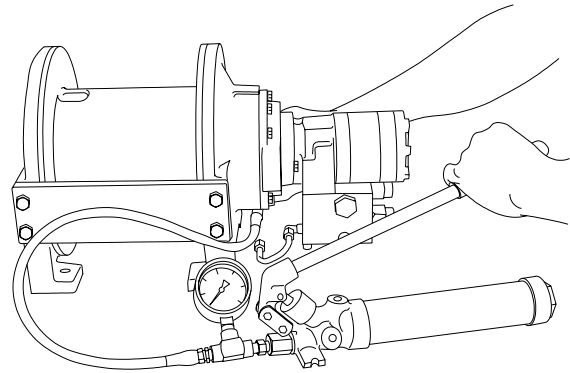

13. Install a hand pump with an accurate 0-2,000 psi (0-13,800 kPa) gauge and shut-off valve to the brake release port. Apply 1,000 psi (6,900 kPa) to the brake and close the shut-off valve. Let the brake stand for five (5) minutes. If there is any loss of pressure, the brake pack should be disassembled for inspection of the sealing surfaces and the brake piston. Release the pressure, remove the hand pump and install the brake release tube (43) between the brake valve block (39) and the brake release port.

RECOMMENDED FASTENER TORQUE

The general purpose torque shown in the chart applies to SAE Grade 5 bolts, studs and standard steel full, thick and high nuts.

Higher or lower torques for special applications will be specified such as the use of spanner nuts, nuts on shaft ends, jam nuts and where distortion of parts or gaskets is critical.

Lubricated Torque values based on use of SAE 30wt engine oil applied to threads and face of bolt or nut.

Avoid using thread lubricants as the applied torque may vary by 10-40% depending upon product used.

BOLT DIA. INCHES	THD PER INCH	TORQUE LB-FT. (N·m)	
		DRY	LUBED
1/4	20	9	6
	28	(12)	(8)
5/16	18	18	13
	24	(24)	(18)
3/8	16	31	23
	24	(42)	(31)
7/16	14	50	37
	20	(68)	(50)
1/2	13	75	55
	20	(102)	(75)
9/16	12	110	80
	18	(149)	(109)
5/8	11	150	115
	18	(203)	(156)

BOLT DIA. INCHES	THD PER INCH	TORQUE LB-FT. (N·m)	
		DRY	LUBED
3/4	10	265	200
	16	(359)	(271)
7/8	9	420	325
	14	(569)	(441)
1	8	640	485
	14	(868)	(658)
1 1/8	7	790	590
	12	(1071)	(800)
1 1/4	7	1110	835
	12	(1505)	(1132)
1 3/8	6	1460	1095
	12	(1980)	(1485)
1 1/2	6	1940	1455
	12	(2630)	(1973)

To convert lb. ft. to kg·m, multiply lb. ft. value by 0.1383.

METRIC CONVERSION TABLE

MULTIPLY:	BY:	TO GET:	MULTIPLY:	BY:	TO GET:
LINEAR					
inches (in.)	× 25.4	= millimeters (mm)	× 0.03937		= inches (in.)
feet (ft.)	× 0.3048	= meters (m)	× 3.281		= feet (ft.)
miles (mi.)	× 1.6093	= kilometers (km)	× 0.6214		= miles (mi.)
AREA					
inches ² (sq.in.)	× 645.15	= millimeters ² (mm ²)	× 0.000155		= inches ² (sq.in.)
feet ² (sq.ft.)	× 0.0929	= meters ² (m ²)	× 10.764		= feet ² (sq.ft.)
VOLUME					
inches ³ (cu.in.)	× 0.01639	= liters (l)	× 61.024		= inches ³ (cu.in.)
quarts (qts.)	× 0.94635	= liters (l)	× 1.0567		= quarts (qts.)
gallons (gal.)	× 3.7854	= liters (l)	× 0.2642		= gallons (gal.)
inches ³ (cu.in.)	× 16.39	= centimeters ³ (cc)	× .06102		= inches ³ (cu.in.)
feet ³ (cu.ft.)	× 28.317	= liters	× 0.03531		= feet ³ (cu.ft.)
feet ³ (cu.ft.)	× 0.02832	= meters ³ (m ³)	× 35.315		= feet ³ (cu.ft.)
fluid oz. (fl. oz)	× 29.57	= milliliters (ml)	× 0.03381		= fluid oz. (fl.oz.)
MASS					
ounces (oz.)	× 28.35	= grams (g)	× 0.03527		= ounces (oz.)
pounds (lbs.)	× 0.4536	= kilograms (kg)	× 2.2046		= pounds (lbs.)
tons (2000 lb.)	× 907.18	= kilograms (kg)	× 0.001102		= tons (2000 lb.)
tons (2000 lb.)	× 0.90718	= metric tons (t)	× 1.1023		= tons (2000 lb.)
tons (long) (2240 lb)	× 1016.05	= kilograms (kg)	× 0.000984		= tons (lg) (2240 lb.)
PRESSURE					
inches Hg (60°F)	× 3600	= kilopascals (kPa)	× 0.2961		= inches Hg
pounds/sq.in. (PSI)	× 6.895	= kilopascals (kPa)	× 0.145		= pounds/sq.in. (PSI)
pounds/sq.in. (PSI)	× .0703	= kilograms/sq.cm (kg/cm ²)	× 14.22		= pounds/sq.in. (PSI)
pounds/sq.in. (PSI)	× .069	= bars	× 14.50		= pounds/sq.in. (PSI)
inches H ₂ O (60°F)	× 0.2488	= kilopascals (kPa)	× 4.0193		= inches H ₂ O
bars	× 100	= kilopascals (kPa)	× 0.01		= bars
POWER					
horsepower (hp)	× 0.746	= kilowatts (kW)	× 1.34		= horsepower (hp)
ft.-lbs./min	× 0.0226	= watts (W)	× 44.25		= ft.-lbs./min.
TORQUE					
pound-inches(in.-lbs.)	× 0.11298	= newton-meters (N•m)	× 8.851		= pound-inches (in.lb.)
pound-feet (ft.-lbs.)	× 1.3558	= newton-meters (N•m)	× 0.7376		= pound-feet (ft.-lb.)
pound-feet (ft.-lbs.)	× .1383	= kilograms/meter(kg•m)	× 7.233		= pound-feet (ft.-lb.)
VELOCITY					
miles/hour (m/h)	× 1.6093	= kilometers/hour (km/hr)	× 0.6214		= miles/hour (m/h)
feet/sec. (ft./sec.)	× 0.3048	= meter/sec. (m/s)	× 3.281		= feet/sec. (ft./sec.)
feet/min. (ft./min.)	× .3048	= meters/min. (m/min)	× 3.281		= feet/min. (ft./min)

TEMPERATURE °Celsius = 0.556 (°F - 32) °F = (1.8°C) + 32

COMMON METRIC PREFIXES	mega (M) = 1,000,000 or 10 ⁶	deci (d) = 0.1 or 10 ⁻¹
	kilo (k) = 1,000 or 10 ³	centi (c) = 0.01 or 10 ⁻²
	hecto (h) = 100 or 10 ²	milli (m) = 0.001 or 10 ⁻³
	deka (da) = 10 or 10 ¹	micro (μ) = 0.000.001 or 10 ⁻⁶

